

# RADIANT

ARCHITECTURAL LIGHTING

North American Edition

2022

# RADIANT

## ARCHITECTURAL LIGHTING

Radiant Architectural Lighting has entered the North American market.

We have partnered with Illumination Management, LLC. Illumination Management's facility in New York is certified with ETL and UL testing labs. IM provides warehousing, manufacturing, assembly, customer service, engineering and technical support to its partners and the architectural lighting market in Canada, the United States, Mexico, and the Caribbean.

Mark Carroll and his team will be the point of contact for Radiant in North America.

Innovative design is at the heart of everything Radiant does. Our founder and Managing Director, David Morgan, has been a luminaire designer for 40 years bringing knowledge, expertise and creativity to Radiant Architectural Lighting.

The company uses the latest lighting technologies to produce durable and efficient lighting systems that deliver visually stunning results. Radiant's products are designed to be flexible, versatile, discreet and are frequently concealed, creating lit effects that enhance beautiful interior and exterior architectural features and eye-catching sculptures. And that's just as it should be.

Radiant Lighting has provided innovative lighting for projects in over 30 countries. Working with leading lighting designers and architects, the products can be adapted and configured to suit any needs enhancing architecture subtly and beautifully, giving clients the tools they need to create perfectly illuminated spaces.

The highly experienced Radiant luminaire development team has designed a product portfolio which offers flexibility, adjustability and unrivalled performance. No matter how complex the project, Radiant is likely to be the perfect partner for your lighting requirements and, together with Illumination Management, we can support the needs of US designers from concept through to commissioning.

We love a lighting challenge, and we look forward to working with you.

# 3D LED Flex Range

## Modular + Linear + 3D Flexible

The multi-award winning 3D LED Flex system has developed from a custom solution for a Zaha Hadid designed building into a comprehensive modular linear lighting system with a vast range of options.

Ideal for use in a wide range of interior, exterior and underwater lighting projects where curved lines of light are needed to illuminate non-linear building surfaces, columns and domes.

The patented mechanical joint structure allows the individual modules to be bent and twisted in three dimensions to follow the most complex building contours.

- Flexible in 3 Dimensions & hand-bendable and lockable on-site
- Four sizes, for projects of all sizes. Up to 3,300 lumens per ft from the 200 size down to 1,200 lumens per ft from the 25.
- IP ratings of IP20, IP44, IP65, IP66 and IP68 submersible
- A wide range of LED light engine, reflector and lens options available. White light, RGB, RGBW, and dynamic white options available
- Wide range of bracketry and anti-glare accessories. Custom lengths up to 8.3' based on a 4" or 8" module length

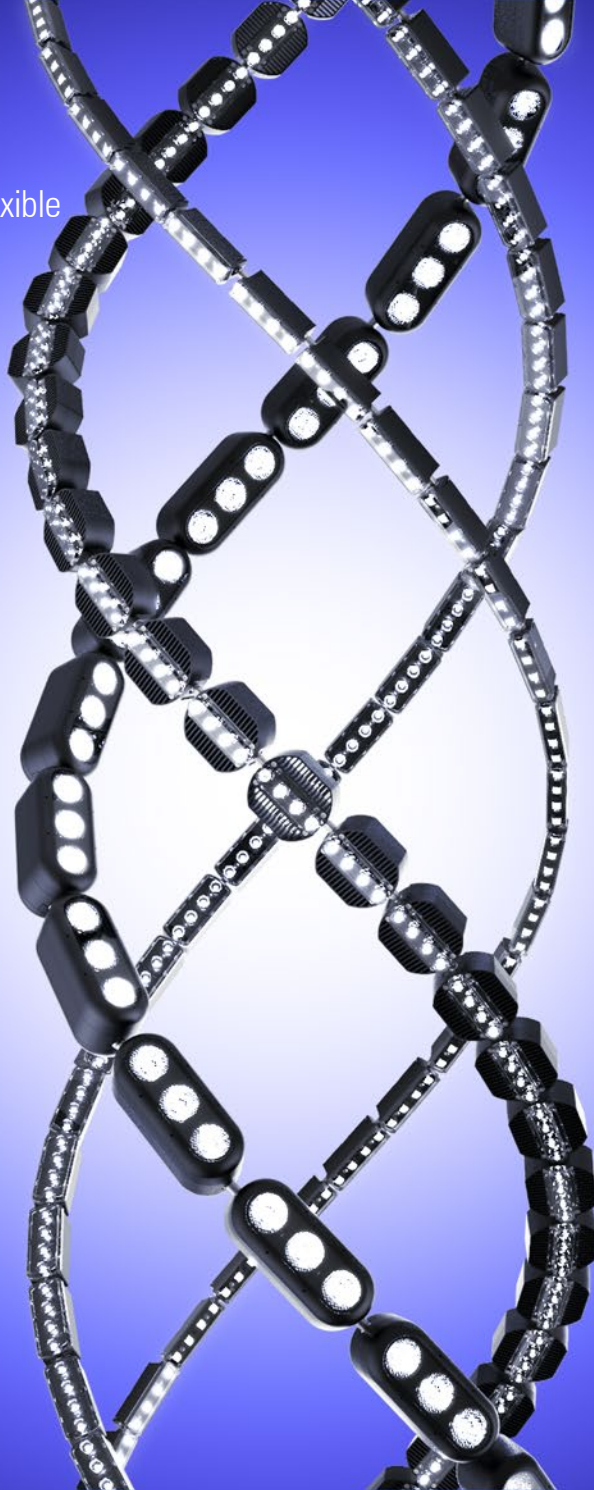

## 3D LED Flex 200

- Up to 3,300 lumens per ft
- Up to 25 Watts per 8" module
- IP ratings available: IP20, IP65 & IP66



## 3D LED Flex 100

- Up to 2,800 Lumens per ft
- Up to 11 Watts per 4" module
- IP ratings available: IP20, IP65 & IP66



## 3D LED Flex 40

- Up to 1,500 Lumens per Mtr
- Up to 5 Watts per 4" module
- IP ratings available: IP20, IP44, IP65, IP66 & IP68



## 3D LED Flex 25

- 1,200 lumens per ft
- Up to 4 Watts per 4" module
- IP ratings available: IP20, IP65, IP66 & IP68



# 3D LED Flex Range

Modular + Linear + 3D Flexible

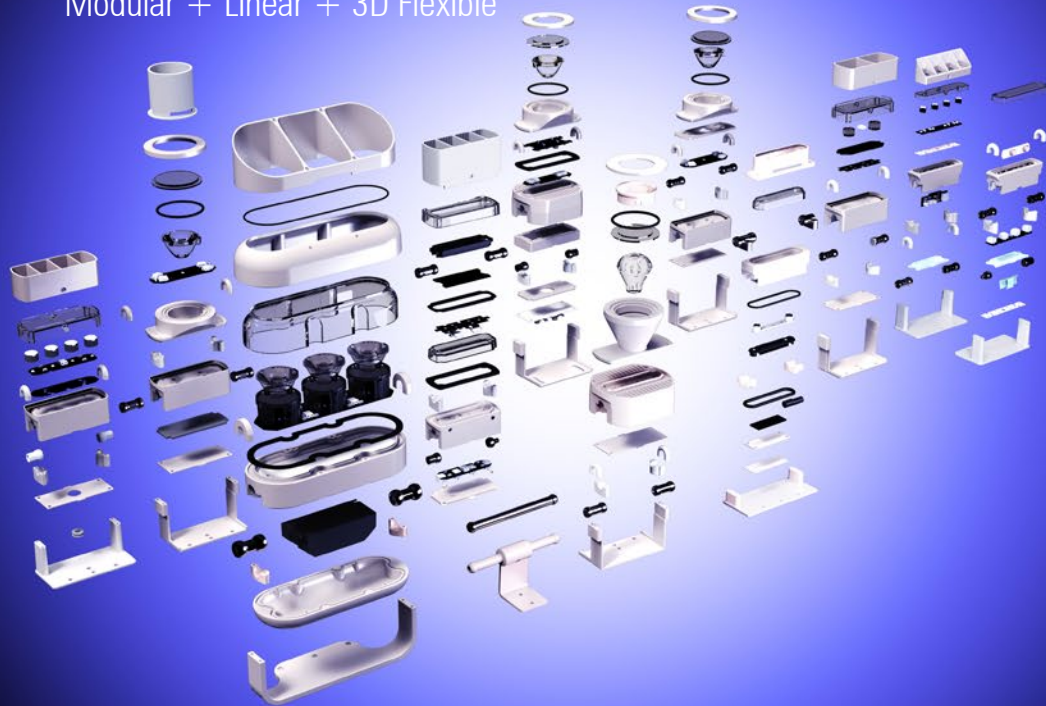

The 3D LED Flex range is modular and the various components can be assembled together in different combinations to meet project requirements. Every element from the light engine and optics, to the anti-glare accessories and bracketry can be customised. We are continuously developing new components for the system as the scope of our projects expands.



Twin module



Two-level bracket



Single modules on adjustable angle brackets



Wider spaced modules with extended ball-joints

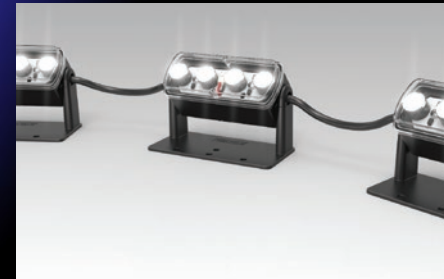

Single modules with flexible cable link



Customisable anti-glare accessories



Custom finishes for metalwork and louvres



Custom light engines and optics for each project

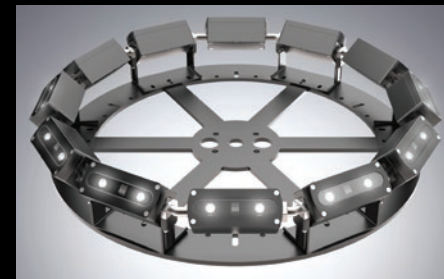

Custom bracket solutions



Custom strip lengths up to 8.2' (2.5 Mtrs)

# 3D LED Flex 200 IP66

## Modular, 3D flexible LED exterior linear lighting system

The 3D LED Flex 200 IP66 system has been developed for use in a wide variety of large-scale exterior architectural lighting projects requiring wall grazing and wall wash lighting where the building surfaces are non-linear with curved profiles and facades.

The patented articulated ball-joint system joining the heat-sink modules allows the system to follow complex curved building profiles.

The latest and largest addition to the range, the 3D LED Flex 200 can be run at up to 38 Watts per ft (up to 125 Watts per mtr), providing Up to 3,300 lumens per ft (up to 11,000 Lumens per mtr).

Each 8" (200mm) long module comprises 3 x arrays of 4 x RGBW Luxeon CZ LEDs with highly efficient Gaggione colour-blending lenses.

Integral AC to DC constant current drivers allow long lengths to be powered from a single power feed.

Dimming interfaces include DALI, DMX, and 1-10V.

The system has no visible fixings and anti-glare snoots provide excellent glare control.



Up to 3,300 lumens per ft



3D LED Flex 200 IP 66

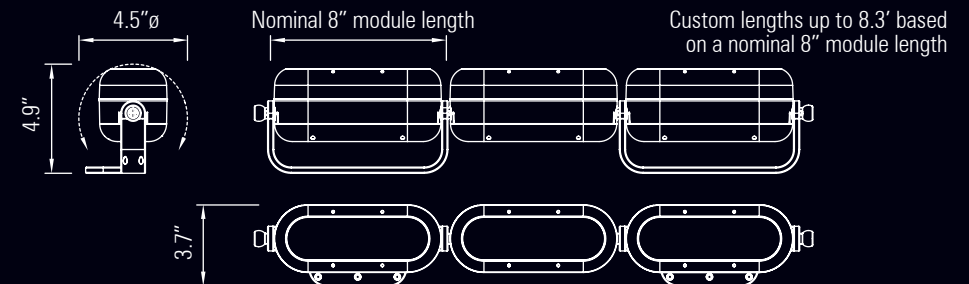

## 3D LED Flex 100 IP20

### Modular, 3D flexible LED interior linear lighting system

The Radiant 3D LED Flex 100 system was the first type in the range and was originally developed for the Zaha Hadid designed Heydar Aliyev Centre project to provide all ambient lighting in the auditorium. The system has been further developed for use in a wide variety of other architectural lighting projects requiring cove lighting and wall wash lighting where the building surfaces are non-linear with curved profiles and facades.

The patented articulated joint system joining the heat sinks allows the system to follow curved building surfaces while maintaining a 1" spacing between LEDs, thus ensuring continuous lit effects without shadows or dark areas.

Each LED heat sink module can operate up to 11 Watts of LEDs giving a light output of over 2,800 lumens per ft.

Integrated LV DC to DC constant current drivers allow long runs to be powered from a single remote power supply.

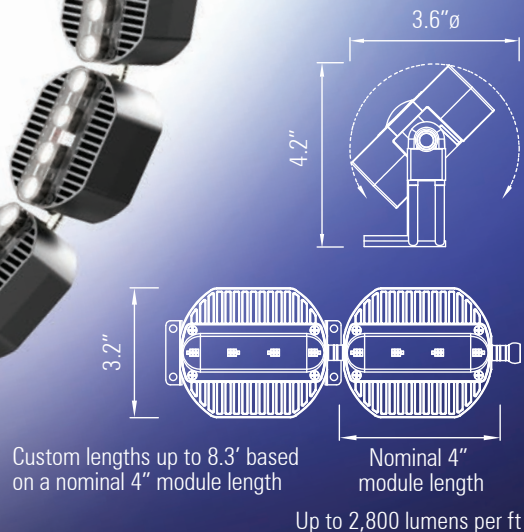

Heydar Aliyev Centre  
Architect Zaha Hadid Associates  
Lighting design by MBLD



Burberry flagship store, Regent Street, London. Lighting design by Russell Lipscombe



28 x 0.3 W medium power LEDs with white reflector per module



4 x high power LEDs with lenses per module

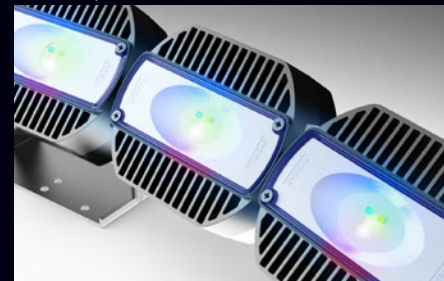

1 x 10 Watt RGBW LED array with asymmetric reflector per module



1 x 10 Watt RGBW LED array with colour-blending lens per module



The McEwan Hall, University of Edinburgh. Lighting design by Buro Happold



Swindon Designer Outlet, UK. Architecture by McLaren & POD. Lighting design by Aecom

# 3D LED Flex 100 IP66

## Modular, 3D flexible LED exterior linear lighting system

The Radiant 3D LED Flex 100 IP66 system has been developed for use in larger scale exterior lighting applications where the building surfaces are non-linear with curved profiles including columns, domes and curved facades.

The articulated joint system allows the LED heat sinks to follow three dimensionally curved surfaces while maintaining a 1" spacing between LEDs, thus ensuring continuous lit effects without shadows or dark areas.

A digital thermal control system ensures that the LEDs work at an optimal temperature even in high ambients.



Up to 2,600 lumens per ft



Ultra narrow beam 4 degree lenses



Intu Lakeside Shopping Centre. Lighting design by Hoare Lea



## 3D LED Flex 40 IP20

Modular, IP20 3D flexible LED interior linear lighting system

The Radiant 3D LED Flex 40 IP20 system incorporates the widest range of versions and options and has been specified and installed on the greatest number of projects to date.

The system can be run at 16 Watts per ft and provides over 1,500 lumens per ft depending on LED colour temperature and type.

The system includes both interior IP20, exterior IP66 and underwater IP68 versions.



**GERMAN  
DESIGN  
AWARD  
WINNER  
2019**

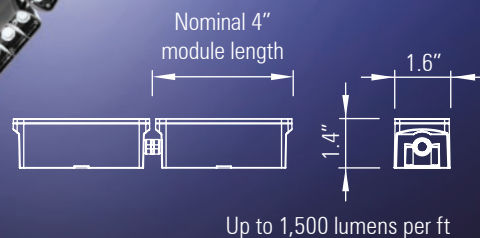

WestQuay Watermark, UK  
Lighting design by George Sexton Associates



Dior store in Centria mall, Riyadh  
Lighting design by Metis lighting



3D LED Flex 40 IP20. High-power LEDs with optics



Amara Hotel, Cyprus. Lighting design by Light 360



K11 Musea, Hong Kong. Lighting design by Speirs + Major. Photography by Jackie Chan



Virgin Voyages' Scarlet Lady cruise ship

Lighting design by Cinimod  
Photography by Virgin Voyages



Hammersmith Apollo London, foyer & auditorium



Lighting design by Jim Morse Lighting



3D LED Flex 40 IP20 RGBW - colour-mixing optic

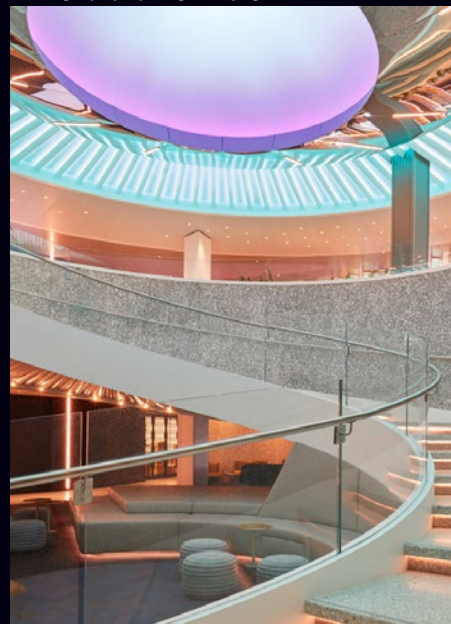

3D LED Flex 40 IP20 RGBW - mini colour-mix optic



3D LED Flex 40 IP20 RGBW - white reflector

## 3D LED Flex 40 IP66

### Modular, IP66 3D flexible LED exterior linear lighting system

One of the early developments of the 3D LED Flex 40 system was an exterior IP66 rated version so that the same system can be used to light both interior and exterior projects. The system has also been used to light pools and hammams where high humidity would cause problems for an IP20 rated system.

The most popular elliptical optic version has been used to graze domes, curved roof surfaces and facades. The nominal 4" module allows the system to be tailored to fit any building size and shape.

The system can be run at up to 16 Watts per ft and provides over 1,500 lumens per ft. With many options for LED light engines, optics, mounting brackets and anti-glare accessories the system can be configured for each project.

A thermal control system is used in high ambient conditions to keep the LEDs working at an optimum temperature.

Up to 1,500 lumens per ft



University of Edinburgh Old College dome  
Lighting design by Nich Smith Lighting Design



The Bvlgari Spa, Dubai. Lighting design by Delta lighting solutions, Dubai  
Winner of the Light Middle East Award for Hotel Lighting Project of the Year



Deniz Mall, Baku, Azerbaijan  
Lighting design by MBLD



3D LED Flex 40 IP66 system. Each module comprises 4 x Luxeon Z red LEDs with a Gaggione ultra-narrow beam lens, and custom height anti-glare snoot. Each module is individually addressable via DMX

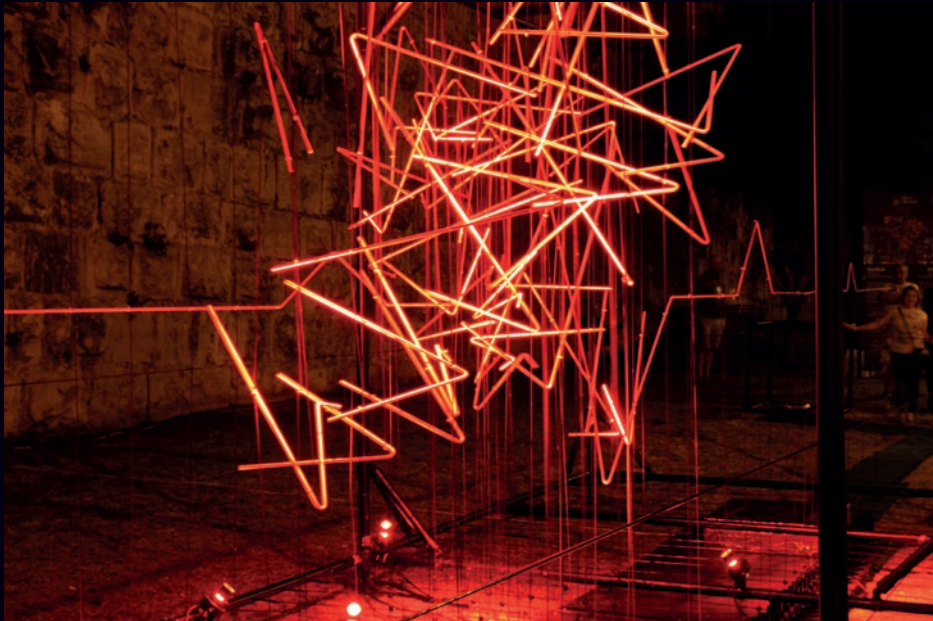

Heart Beat installation. Lighting design by GNI Projects

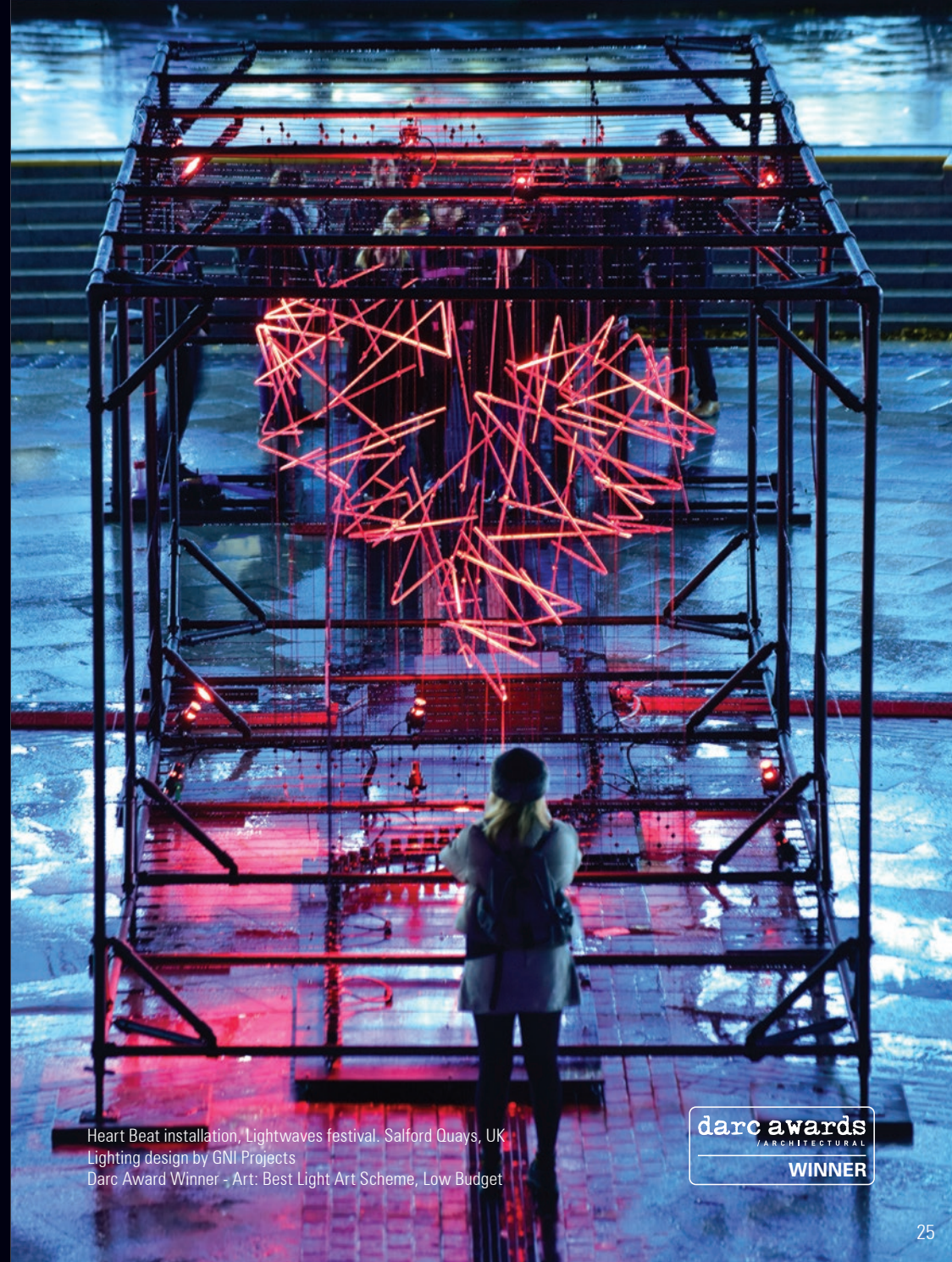

Heart Beat installation, Lightwaves festival. Salford Quays, UK  
Lighting design by GNI Projects  
Darc Award Winner - Art: Best Light Art Scheme, Low Budget





3D LED Flex 40 System IP66 RGBW - 200 mm module pitch  
Each module is individually addressable via DMX



South Devon College, UK. Lighting design by Michael Grubb Studio. Photograph by Tom Davey



8 or 12 x 0.3 Watt medium power LEDs with white reflector per module



4 x high power LEDs with lenses per module



1 x RGBW or Tunable white array with colour-blending lens per module



1 x RGBW array with reflector per module



1 x high power LED with ultra-narrow beam spot or ultra-narrow elliptical beam lens per module



1 x RGBW or Tunable white array with mini colour-blending lens per module

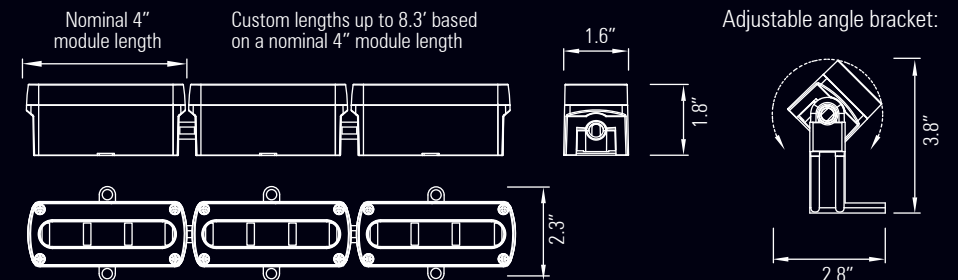

# 3D LED Flex 40 IP68

## Modular, IP68 3D flexible LED underwater linear lighting system

The Radiant 3D LED Flex 40 IP68 system is designed for use in underwater applications where curved lines of light are required. The system components are cast in 316 L stainless steel and are suitable for use in saline and chlorine environments including pools, fountains and marine projects. The pressed glass windows are bonded to the module bodies and all LED and internal driver boards are potted in silicone resin to ensure long working life at up to 2 mtrs depth.

The patented articulated joint system joining the LED modules allows the system to bend and twist in three dimensions to follow curved building surfaces while maintaining a constant spacing between LEDs. Output up to 4,000 lumens per mtr.

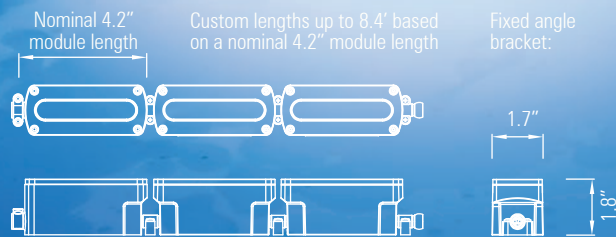

Up to 1,200 lumens per ft

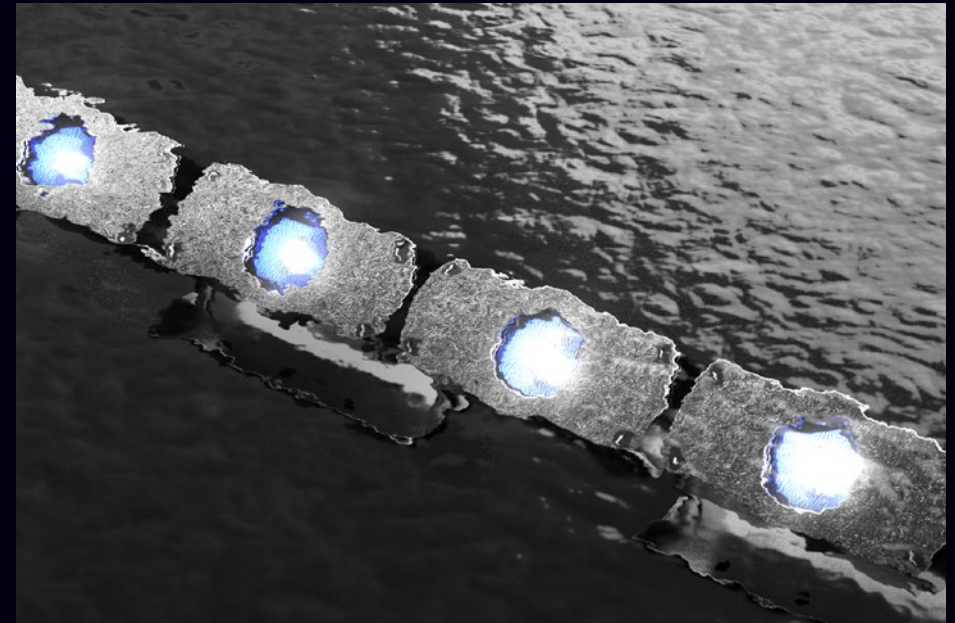

3D LED Flex 40 IP68 RGBW or Tunable white with mini 32 mm diameter colour-blending Gaggione lenses





# 3D LED Flex 25 IP20

## Modular, 3D flexible LED interior linear lighting system

The Radiant 3D LED Flex 25 system incorporates many of the design features of the 100 and 40 systems but with a smaller width of only 1".

The system is ideal for use in smaller architectural, retail and hospitality lighting applications.

This is the most cost effective version of the 3D LED Flex range and has a light output of up to up to 1200 lumens per ft.

Like the larger sizes, the 25 system is available with a wide range of light engines, optics, dimming interfaces, anti-glare accessories and mounting bracketry to suit each project.

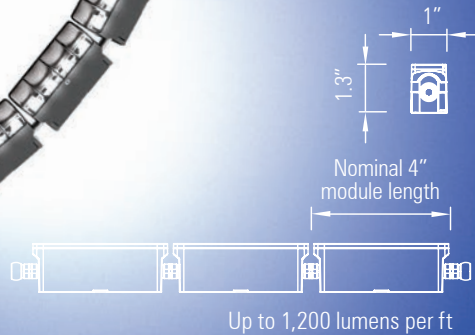

8 or 12 medium power LEDs per module



4 x high power LEDs with lenses per module



Anti-glare snout accessories



200mm double-spacing between modules



Sydney Lyric Theatre, Australia. Lighting design by Schuler Shook

# 3D LED Flex 25 IP66

## Modular IP66 3D flexible LED exterior linear lighting system

The Radiant 3D LED Flex 25 IP66 system is designed to be used in a wide variety of exterior lighting applications where a lower light output and smaller width is needed than the larger types also available in the range.

The system is ideal for use in smaller architectural and facade lighting applications. The system is available in a wide variety of LED, lens and reflector options and can be supplied with pressed glass windows for use in high sunlight situations or where sand abrasion is an issue.

A thermal control system is used in high ambient conditions to keep the LEDs working at an optimum temperature.



Up to 1,100 lumens per ft



Mid-power LED version with adjustable angle brackets



High power LEDs with lenses version with fixed angle mounting brackets



200mm double-spacing between modules



Anti-glare snoot accessories

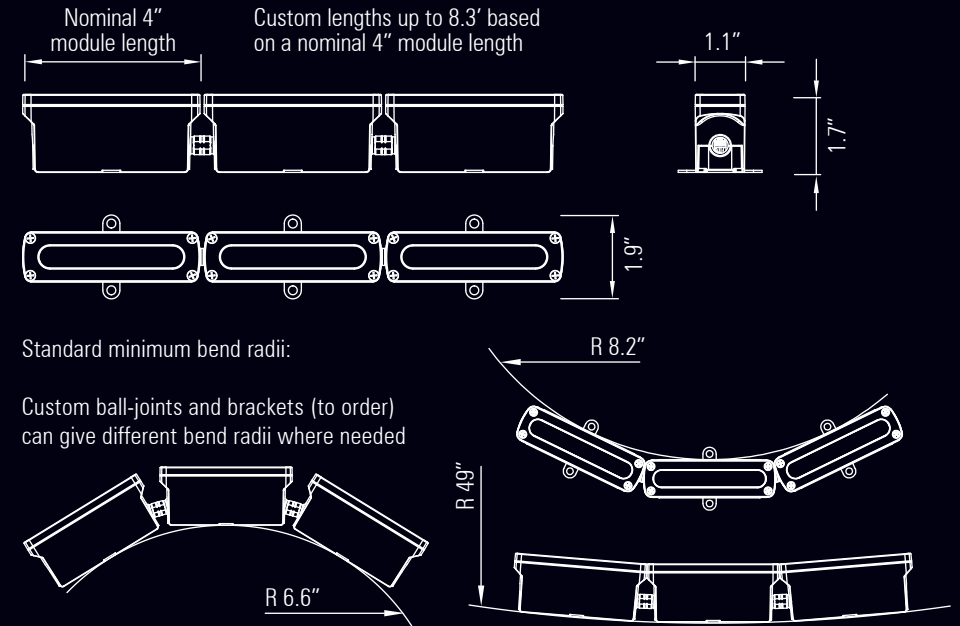

# 3D LED Flex 25 IP68

## Modular IP68 3D flexible LED linear lighting system

The Radiant 3D LED Flex 25 IP68 system is designed for use in underwater applications where the building surfaces are non-linear with curved profiles. The articulated joint system joining the LED heat sinks allows the system to follow curved building surfaces while maintaining a constant spacing between LEDs, thus ensuring continuous lit effects without shadows or dark areas.

The system is submersible up to a depth of 6.6'. The system components are cast in 316 L stainless steel and are suitable for use in saline and chlorine environments including pools, fountains and marine projects. Each module incorporates two Cree XPE LEDs with or without lenses.

The system can be run at 8 Watts per ft and provides up to 600 lumens per ft.

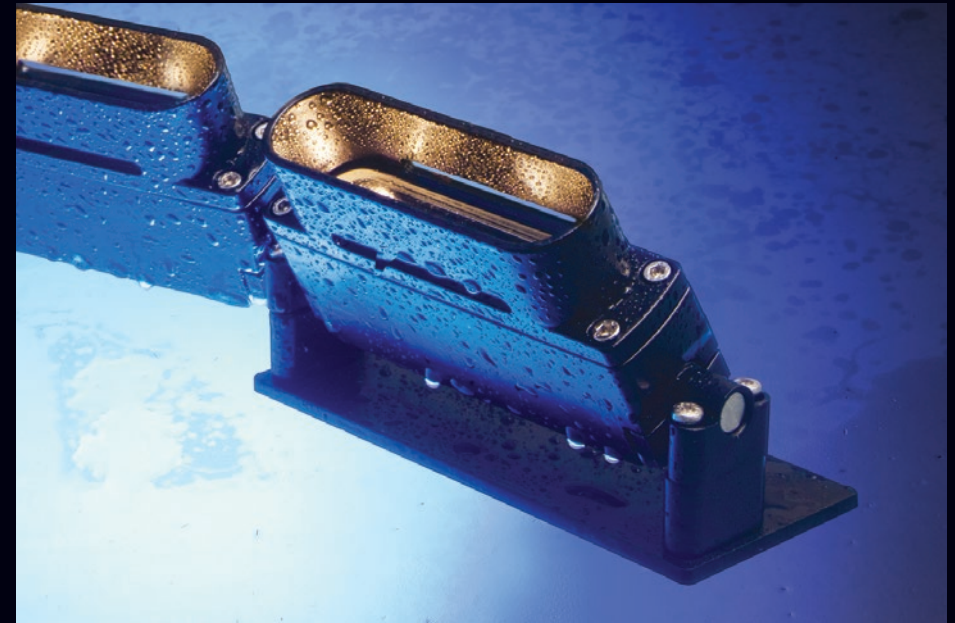
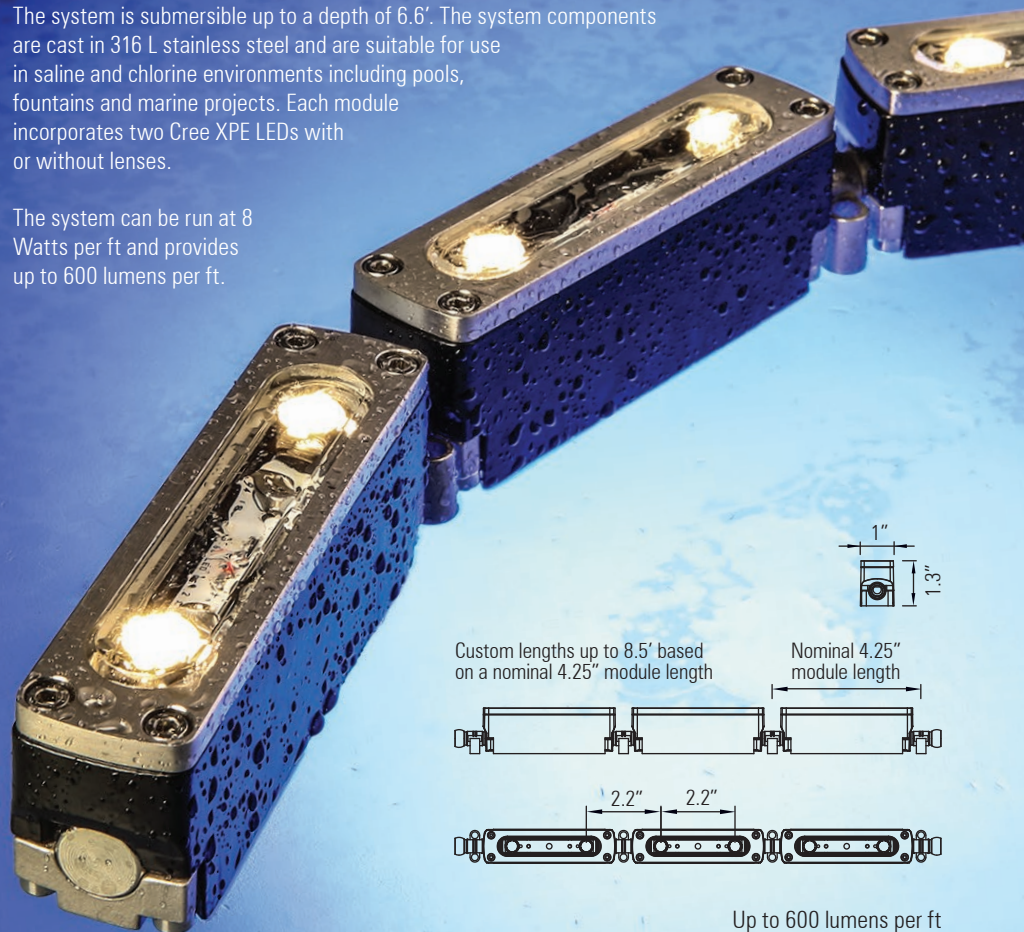

3D LED Flex 25 IP68 with adjustable angle brackets and anti-glare snoot accessory



Chanel Spa at the Ritz Hotel, Paris. Lighting design by Schwinghammer Lighting Design, New York

# Centura

Modular, interior, flexible,  
linear LED pendant system

Centura is a flexible LED interior linear lighting system, designed to make complex designs simple. An innovative design offers the flexibility to follow curved surfaces, encircle columns and domes, and to make irregular shaped pendants, all whilst offering excellent lighting control and uniformity.

The system is available in uplight and downlight and aimable side accent-light solutions, surface mounted or suspended, and with a light output of up to 1,600 lumens per ft, making it ideal for a wide range of application areas including architectural, hospitality, leisure and retail.

The body and anti-glare louvres are available in all RAL colours, including gold for warmth, black for a dark light effect and red for dramatic impact.

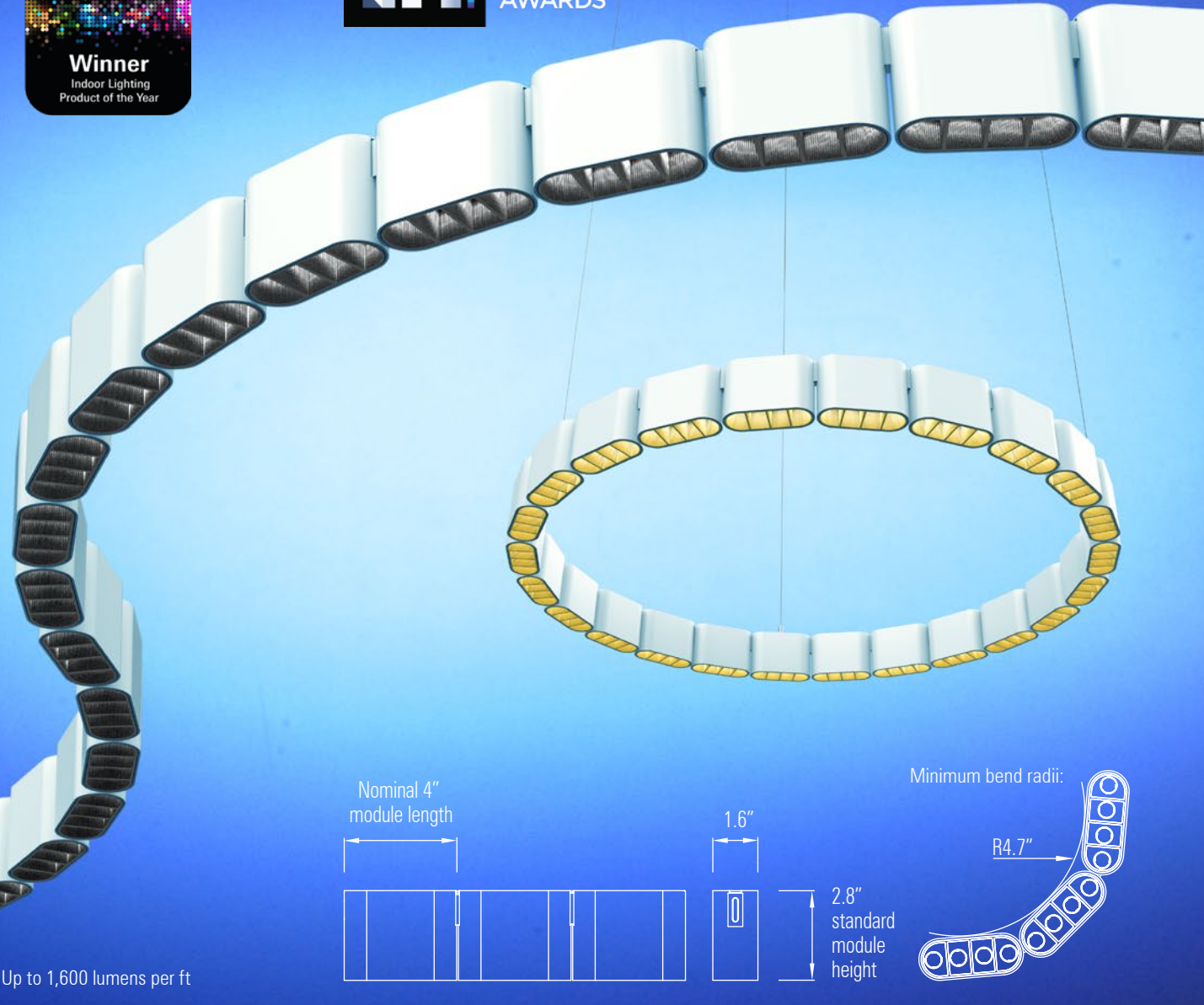
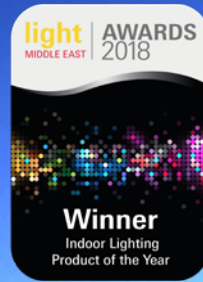

Up to 1,600 lumens per ft

Nominal 4"  
module length

1.6"

2.8"  
standard  
module  
height

Minimum bend radii:

R4.7"

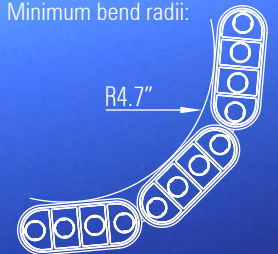

# Centura

Modular, interior, flexible, linear LED pendant system

Downlight, uplight and aimable projector side-light options.  
Flexible articulated modular fixtures  
or custom fixed-shape fixtures.

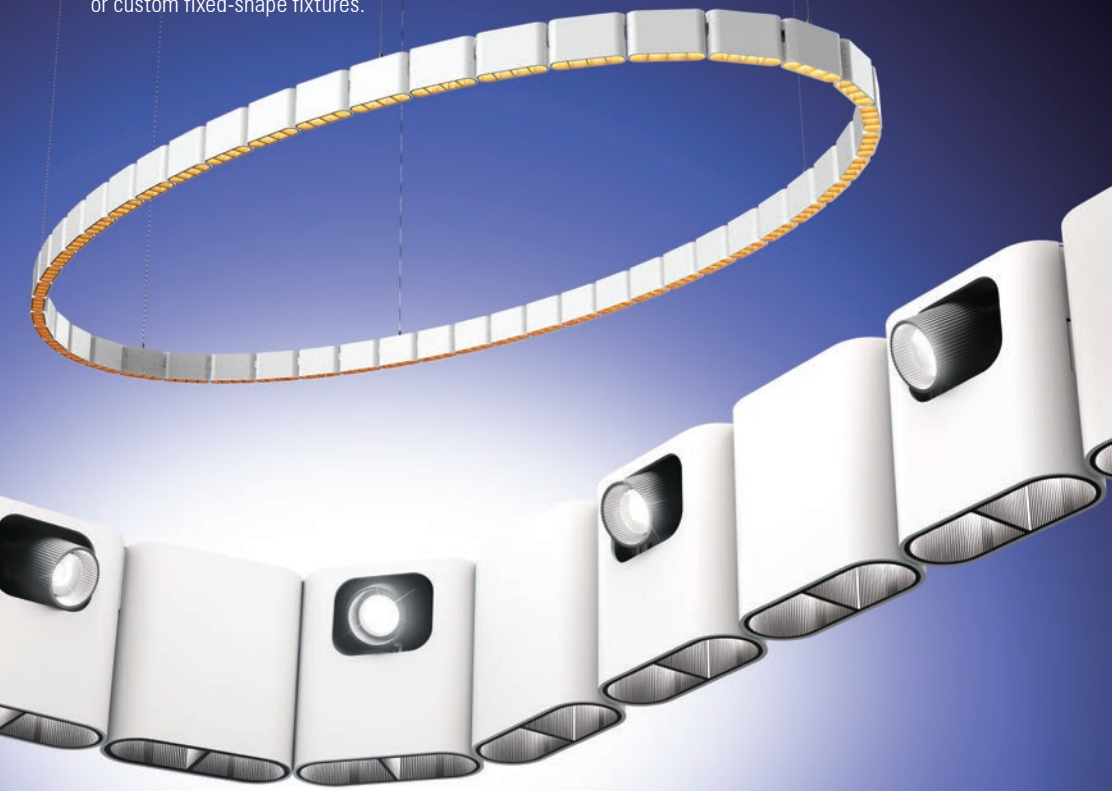

Centura 40 150 IP20 - with opal diffuser

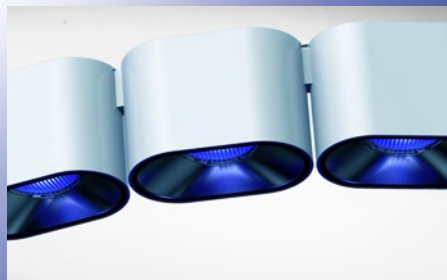

Centura 60 RGBW - with colour-mixing optics



Encompass Control Room, London



Wimpole Street Dental Clinic, London



Lighting design by Syntax Lighting

# Centura

Modular, interior, flexible, linear LED pendant system

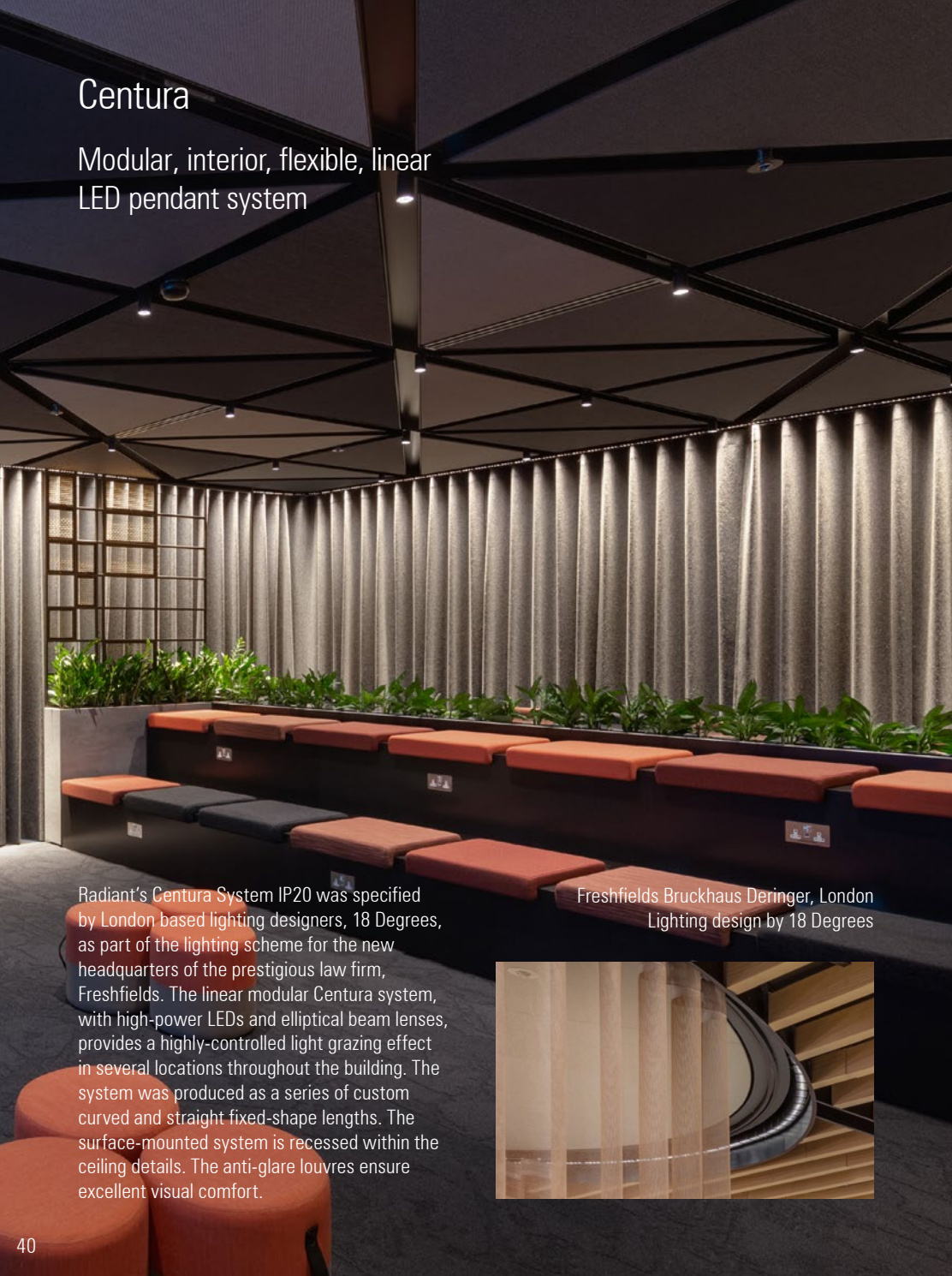

Radiant's Centura System IP20 was specified by London based lighting designers, 18 Degrees, as part of the lighting scheme for the new headquarters of the prestigious law firm, Freshfields. The linear modular Centura system, with high-power LEDs and elliptical beam lenses, provides a highly-controlled light grazing effect in several locations throughout the building. The system was produced as a series of custom curved and straight fixed-shape lengths. The surface-mounted system is recessed within the ceiling details. The anti-glare louvres ensure excellent visual comfort.

Freshfields Bruckhaus Deringer, London  
Lighting design by 18 Degrees



Freshfields Bruckhaus Deringer, London. Lighting design by 18 Degrees



Private residence, London. Lighting design by Syntax lighting

# Euclid 20 Standard and High Output

## LED linear lighting system

The Euclid 20 system was originally developed with DPA in Dubai for use on residential projects as a simple to install, cost effective linear lighting system. The 16 Amp plug together connector system, which fits inside the body extrusion, allows up to 30 ft to be lit from a single feed point without dark gaps between strips.

Designed for use in both indirect cove lighting applications and also, with the addition of a linear lens and optical films, for wall grazing and wall washing.

The system incorporates the same medium power LEDs used in the Shard and Euclid 12 so that all these systems can be used together. Up to 1000 lumens per ft for the high output version. Clear window, Opal and Dot free opal and clear are available along with RGBW and dynamic white light versions.

The system can be supplied in any length up to 8.3 ft with the smallest cutting module based on 4" LED pitch.

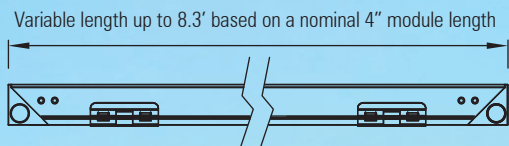
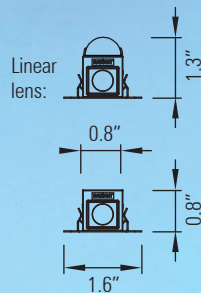

Up to 1,000 lumens per ft

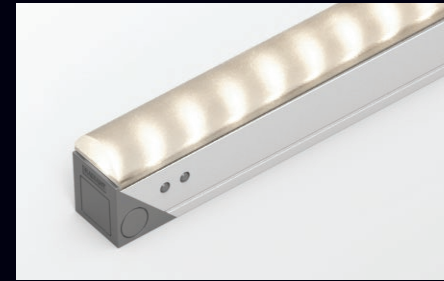

Linear lens version - 40° beam angle



Dot-free version



Plug together 16 Amp connector between strips. Connector fits inside modules for continuous lighting



Euclid 20 side feed



London Heathrow Airport, Terminal 2. Lighting design by Studio Fractal and Hoare Lea. Lux Award winner

# Euclid 20 Balljoint Standard and High Output

## Modular, 3D flexible LED linear lighting system

The Euclid 20 Balljoint system combines the simplicity of the Euclid 20 with the total flexibility of the 3D LED Flex range.

The system incorporates the same medium power LEDs used in the Euclid 20 so that these systems can be used together on the same project. On board linear drivers and LEDs in a wide variety of colour temperatures with CRI up to 95. 1000 lumens per ft for the high output version. Opal, Dot free opal, clear window and linear lens versions are available.

Modules in any length based on a 4" module can be used to make up complete lengths of the system. RGBW and dynamic white light engines can also be incorporated in this system.

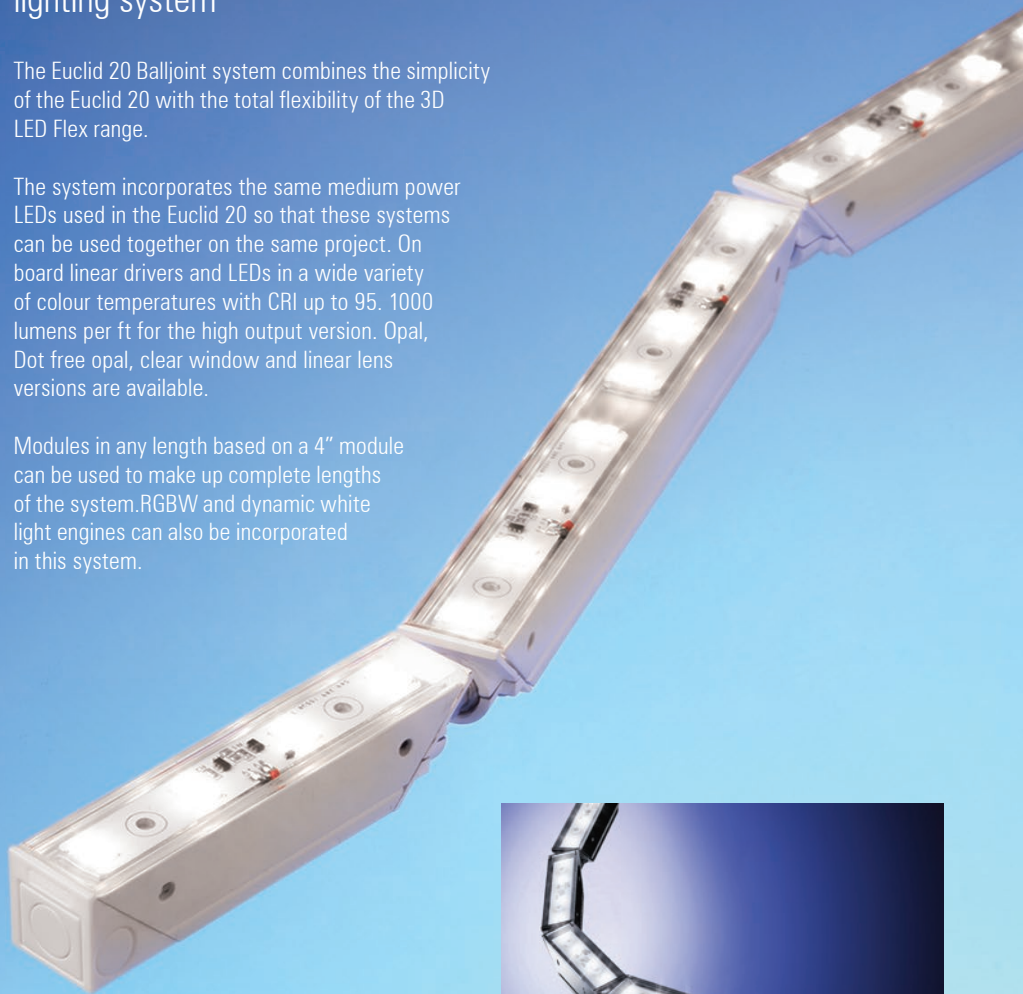

Up to 1,000 lumens per ft

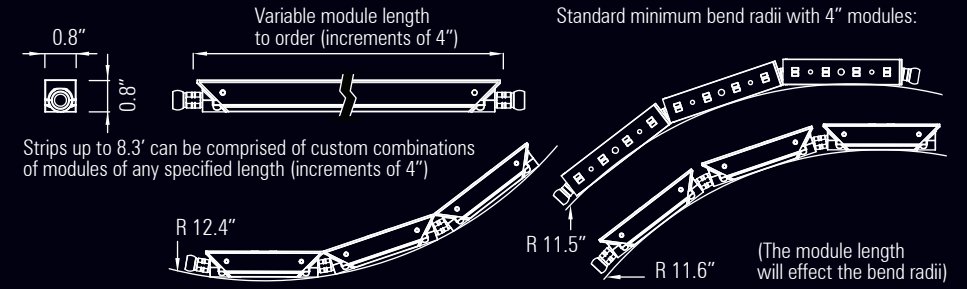

Haz Restaurant, London. Lighting design by Nulty. Shortlisted for Restaurant & Bar Design Awards, Lighting category





# D100 IP20

## LED spotlight range IP20

The D100 range was originally developed for use in the relighting of Hereford Cathedral in conjunction with Light Perceptions. A low profile and excellent glare control were required for this project to ensure that the spotlights were as invisible as possible. There are integral and remote driver versions with one, two or three spotlights per luminaire. A wide variety of anti-glare, beam control and colour filter accessories are available. Fully lockable in both axes.

Up to 1,000 Lumens per spotlight

Remote driver version:

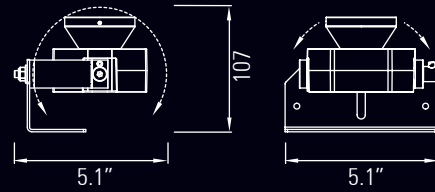

Integral driver version:

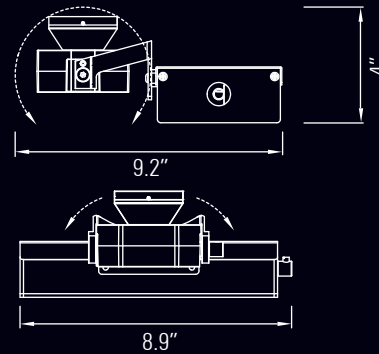

Hereford Cathedral, UK. Lighting design by Light Perceptions



D100 IP20 integral driver version with two spotlight heads

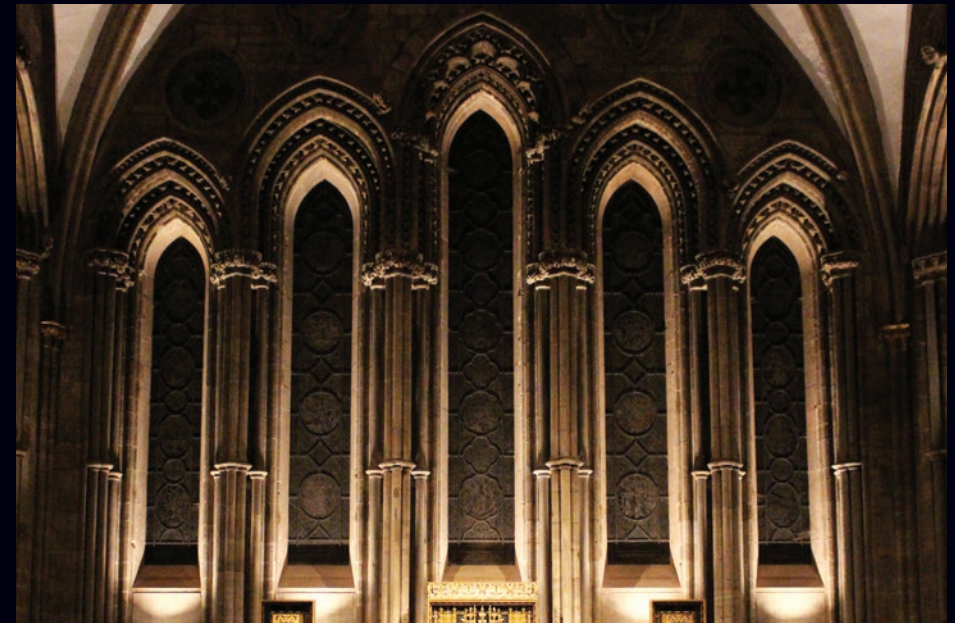

## D100 IP20 Split RGB

LED spotlight range IP20 with separate RGB spotlights

A custom version of the D100 Spotlight IP20 was designed in collaboration with Fabio A P Cristini at There's Light to create a triple colour shadow effect for the BLOK Shoreditch gym in London.

Three spotlight heads, each with different colour LEDs, are mounted to a driver box. Each one comprises 4 x high power LEDs with elliptical Ledil Tina lenses. They can be run at up to 11 Watts each.

Objects which are placed in front of them cast a 3 colour shadow onto the wall behind.



BLOK Shoreditch gym, London.  
Lighting design by Fabio A P Cristini at There's Light



# D100 IP66

## LED accent lighting range IP66

The Radiant D100 system has been developed for use in a wide variety of exterior architectural lighting projects requiring highly controlled accent lighting effects from a compact luminaire. The D100 can operate up to 10 Watts of LEDs, giving a light output of up to 1,000 Lumens. Various LED types and optic configurations are available including RGBW, RGBA and Tunable-white light options. Gaggione's ultra-narrow beam colour-blending lens provides a 6 degree beam when used in conjunction with a cluster array of RGBW or Tunable-white LEDs. Integral LV DC to DC driver and remote AC to DC driver versions are available. A variety of mounting options and anti-glare accessories are also available, making this a highly versatile system.



Up to 1,000 Lumens

Arnhem, Netherlands. Lighting design and project photography by Atelier LEK

Custom versions of the D100 IP66 spotlight system were created in collaboration with Atelier Lek for the master lighting renovation project for the city of Arnhem in Holland. Custom bracketry allow the spotlights to be mechanically integrated into the masts, which were designed and commissioned by Atelier Lek specifically for this project. The brackets allow the spotlights to be rotated and aimed, whilst maintaining a compact form factor. The spotlights comprise of a high power LED light engine with a narrow beam Gaggione lens, which provides highly controlled accent lighting used to illuminate the historic former Post Office building and other architectural highlights around the city centre. Each spotlight can be run at up to 10 Watts, providing up to 1,000 lumens.



# D40 IP66

## LED accent lighting range IP66

The Radiant D40 system has been developed for use in a wide variety of exterior architectural lighting projects requiring highly controlled accent lighting effects from a compact luminaire. The D40 can operate up to 5 Watts of LEDs, giving a light output of up to 500 Lumens. Various LED types and optic configurations are available including RGBW, RGBA and Tunable-white light options. An ultra narrow beam lens can produce a 4° beam. Integral LV DC to DC driver and remote AC to DC driver versions are available. A variety of mounting options and anti-glare accessories are also available, making this a highly versatile system.

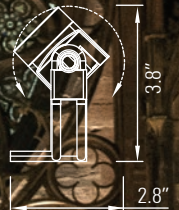

Strasbourg Cathedral, France. Lighting design by Acte Lumiere.  
Darc Award Winner - Structures: Best Exterior Lighting Scheme, High Budget



# Centura module IP20

## LED accent lighting range IP20

The Radiant Centura module IP20 system has been developed for use in a wide variety of architectural lighting projects requiring highly controlled accent lighting effects from a compact luminaire. The Centura module system can be used as wall-lights with up light, down light or up and down light options. Opal diffuser for ambient lighting, or lensed options for wall grazing can create the perfect lit effect to meet the project requirements. The Centura 40 module, which is 100mm in length, or the longer Centura 40 150 module, which is 150mm in length, have a slim profile of 40mm. The larger 60mm wide Centura 60 module, which is 100mm in length, can be specified for projects which require a 45mm diameter Gaggione colour-blending lens. This allows for perfectly blended RGBW and Tunable-white outputs in a range of beam angles, including narrow 8 degree and narrow-elliptical beam options. Centura modules can also be specified as downlight ceiling mounted fixtures. The Centura 40 150 module system can operate up to 7.5 Watts of LEDs per module, giving a light output of up to 800 Lumens. Various LED types and optic configurations are available. Integral LV DC to DC driver and remote AC to DC driver versions are available. Any colour RAL powder coat finish can be specified. Custom mounting solutions can be specified.

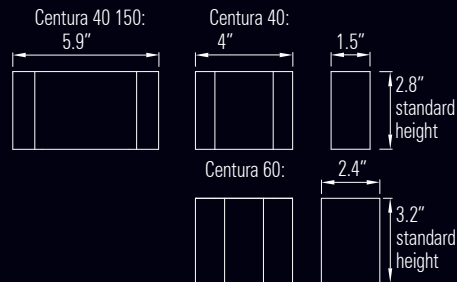

Centura 40 with optics - surface mount - cut-angle  
Centura 40 with optics - up & down wall-light

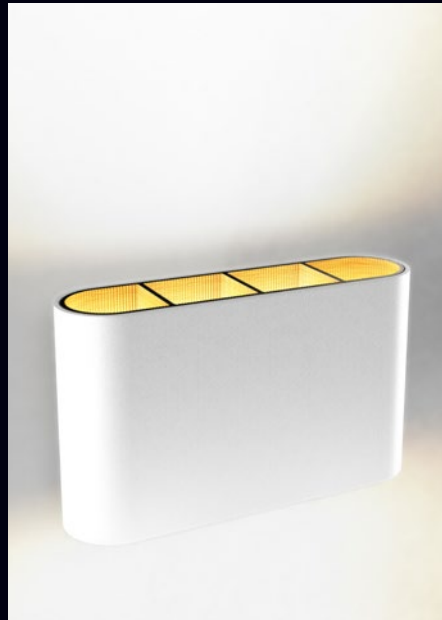

Centura 60 RGBW - wall light - down light  
Centura 40 with diffuser - up & down wall-light



Centura 60 RGBW - ceiling light - down light  
Centura 40 150 with diffuser - up & down wall-light

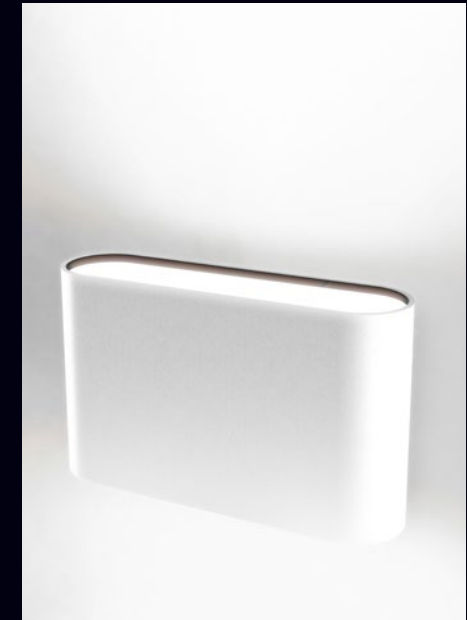

# RADIANT

ARCHITECTURAL LIGHTING

Radiant Architectural Lighting North America

Illumination Management LLC

4750 State Rte 145  
Suite B  
Durham  
NEW YORK  
NY 12422  
USA

TEL 844-403-4059  
TEL 800 714 6272  
TEL 201-562-9298

E MAIL [mcarroll@imlight.net](mailto:mcarroll@imlight.net)  
E MAIL [erica@imlight.net](mailto:erica@imlight.net)  
E MAIL [david@radiantlights.co.uk](mailto:david@radiantlights.co.uk)

WEB [www.radiantarchitectural.lighting](http://www.radiantarchitectural.lighting)



[facebook.com/radiantlightsuk](https://facebook.com/radiantlightsuk)



[twitter.com/radiantlightsuk](https://twitter.com/radiantlightsuk)



[uk.pinterest.com/radiantarch](https://uk.pinterest.com/radiantarch)



[instagram.com/radiantarchitecturallighting](https://instagram.com/radiantarchitecturallighting)